



## MD-PSRM DINergy™ Power Supply Diode Module for Redundant Configuration

(Available December 2006)



Micron DINergy™ power supplies can be connected in parallel to provide redundant rated output power and voltage for fail-safe requirements. To achieve this, a user may connect two identical Micron units with equal output voltage settings, connecting a Micron redundancy module MD-PSRM to prevent back-feeding or looping in the event of failure of one of the units. The MD-PSRM consists of a diode array and sensing/switching components enclosed within a DIN rail mounting metal case, and is equal in size to a 60w DINergy power supply.

- ✧ Common appearance with DINergy™ power supply family
- ✧ Compact size and DIN Rail mounting

Outside Dimension in.(mm)	1.97 (50.0) × 4.13 (105.0) × 4.88 (124.0)
Weight	275g (0.50 lb)

To increase reliability of system, use two power supplies of the same model for redundancy operation. Use load connection wires of the same gauge and length. Set the output voltages of all units to the same values. Connect decoupling diode module MD-PSRM to the positive outputs of the paralleled units. In normal state, each unit provides 50% of load current. When failure occurs on the circuit of the unit 1, unit 2 is able to immediately and automatically replace unit 1 to continue the operation at 100% rated current. The same will be true if the failure occurs on circuit of unit 2.

## Mounting Method

A TS35/7.5 or TS35/15 rail of certain length corresponding to the width of the unit is provided for convenient DIN rail mounting.

## MICRON MD-PSRM CONNECTION DIAGRAM/SCHEMATIC

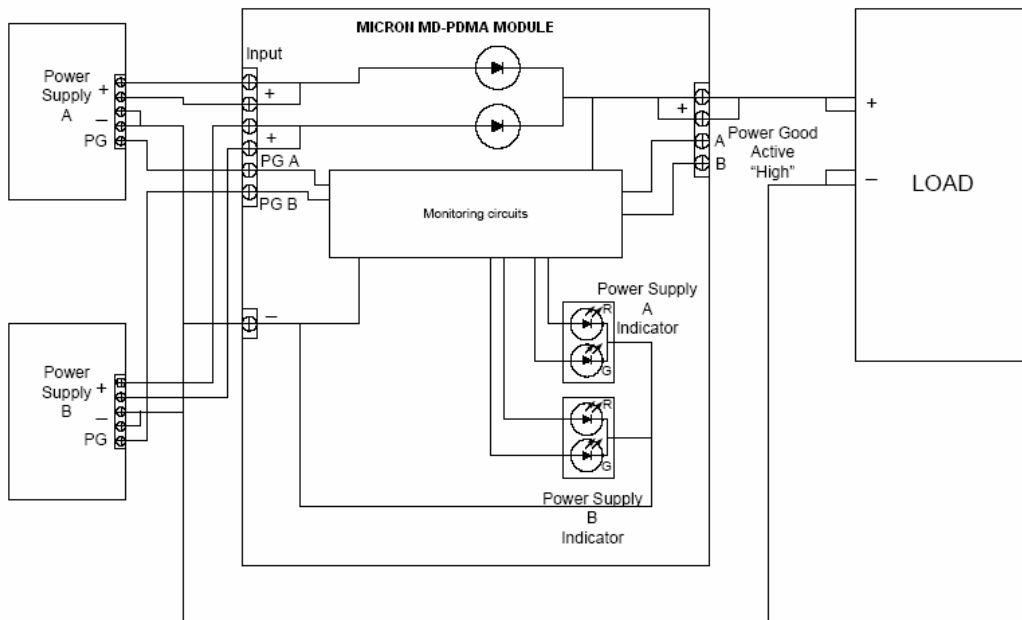

Micron Industries Corporation  
800-664-4660  
info@microntransformers.com  
www.microntransformers.com